

TRUS³AL TSM



+105 °C
↑
-60 °C

IP66

IP67

IP68

IP 69K

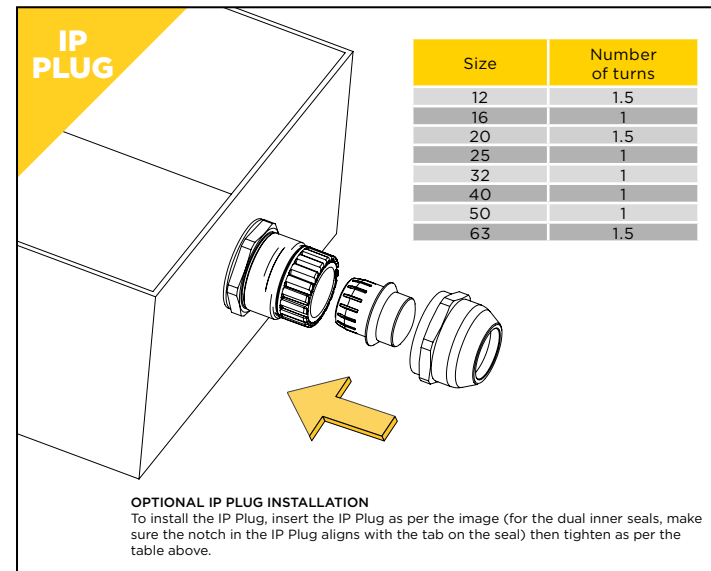
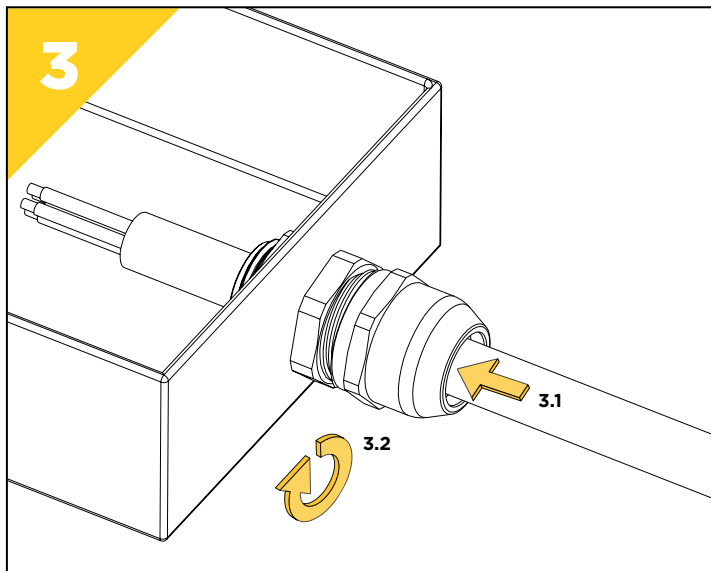
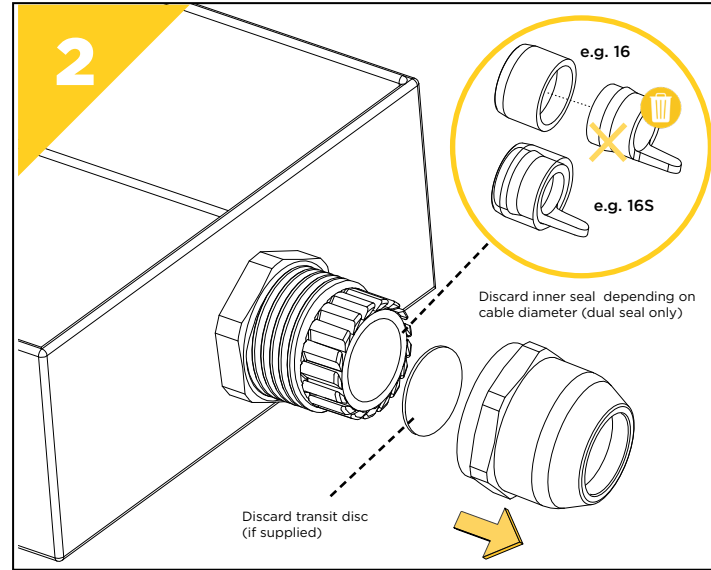
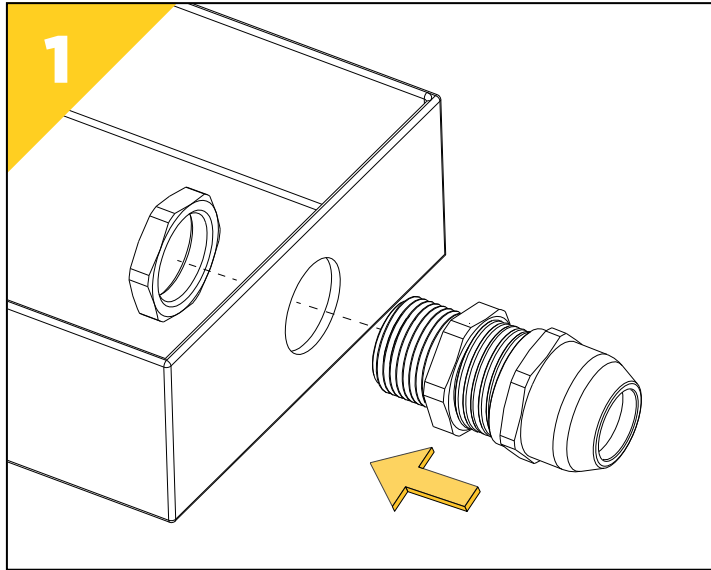

OPTIONAL IP PLUG INSTALLATION
To install the IP Plug, insert the IP Plug as per the image (for the dual inner seals, make sure the notch in the IP Plug aligns with the tab on the seal) then tighten as per the table above.

Cable Gland Size	Hex Size (mm)	Cable Diameter (mm)		Number of Spanner Turns	
		Min	Max	On Min Cable	On Max Cable
12	16	3	6.5	5.5	2
16S	20	3	7	4.2	2
16		6	10	4.5	1
20S	24	5	10	5	2
20		9	14	6	2
25S	30	9	15.5	4.5	1.5
25		12.5	18	5	1
32S	39	12.5	19	4.5	1.5
32		17	25	5.5	1
40S	50	19	27	5	1.5
40		24	32	7	1.5
50S	57	22	32	6.75	1.5
50		28	38	7	1.5
63S	68	28	39	7	1.5
63		37	48	8	1.5

INSTALLATION NOTES:

ENTRY THREADS: PRODUCT SIZE: STANDARD 12 = M12 1/4", 16 = M16 3/8", 20 = M20 1/2", 25 = M25 3/4", 32 = M32 1", 40 = M40 1-1/4", 50 = M50 1-1/2", 63 = M63 2"

ENTRY THREAD LENGTHS: STANDARD 12, 16 = 6mm, 20 = 6.5mm, 25 = 7mm 32, 40 = 8mm, 50 = 9mm 63 = 10mm
LONG 12 - 32 = 12mm, 40 - 63 = 15mm

MAXIMUM CLEARANCE HOLE SIZE: 12 - 25 = 0.2mm, 32 - 40 = 0.3mm, 50 - 63 = 0.4mm ABOVE THE MAJOR THREAD DIAMETER

CABLE ANCHORAGE: TYPE 'A',

IMPACT RATING: CATEGORY 6