

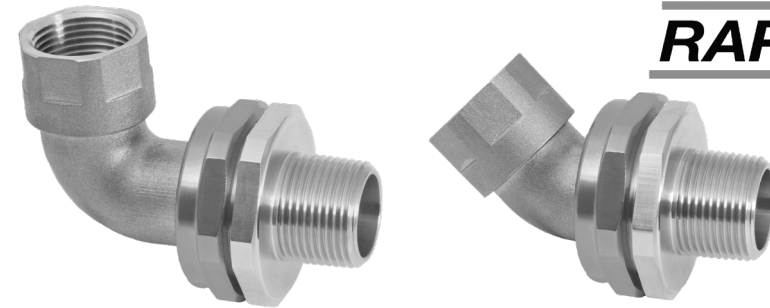

# INSTALLATION INSTRUCTIONS FOR UNION TYPE PX789REX & PX784REX

UNION TYPE PX789 FOR CONNECTING CONDUITS TO ENCLOSURES OR CONDUITS TO EACH OTHER USING RAPIDEX RESIN AT 90° AND 45° ANGLES IN EXPLOSIVE ATMOSPHERES.

## INCORPORATING EU DECLARATION OF CONFORMITY TO DIRECTIVE 2014/34/EU AND UK STATUTORY REQUIREMENTS SI 2016 No. 1107 (AS AMENDED)



### TECHNICAL DATA

**ADAPTOR TYPE** : PX789 PX784  
**INGRESS PROTECTION** : IP66 when used with CMP sealing accessories  
**PROCESS CONTROL SYSTEM** : BS EN ISO 9001 - 2000  
 : ISO/IEC 80079-34:2011

### EXPLOSIVE ATMOSPHERES CLASSIFICATION

**ATEX CERTIFICATION No** : CML 18ATEX1329U  
**ATEX CERTIFICATION CODE** : II 2G 1D Ex db IIC Gb, Ex eb IIC Gb, Ex ta IIIC Da IP6X  
 : II 2G 1D Ex db I Mb / Ex eb I Mb  
**UKEX CERTIFICATION No** : CML 21UKEX1242U  
**UKEX CERTIFICATION CODE** : II 2G 1D Ex db IIC Gb, Ex eb IIC Gb, Ex ta IIIC Da IP6X  
 : II 2G 1D Ex db I Mb / Ex eb I Mb

**IECEX CERTIFICATION No** : IECEX CML 18.0186U  
**IECEX CERTIFICATION CODE** : Ex db IIC Gb, Ex eb IIC Gb, Ex db I Mb, Ex ta IIIC Da IP6X  
**cCSAus CERTIFICATION No** : 1055233  
**CODE OF PROTECTION** : Class I, Div 1 & 2, Groups A,B,C,D; Enclosure Type 4X : Class I Zone 1, AEx de II; Ex de II

### INSTALLATION INSTRUCTIONS

- Installation should only be performed by a competent person using the correct tools. Spanners should be used for tightening. Read all instructions before beginning installation.
- The interface between a cable entry device and its associated enclosure / cable entry will require additional sealing to achieve ingress protection (IP) ratings higher than IP54. The minimum protection level is IP54 for explosive gas atmospheres and IP6X for explosive dust atmospheres. Parallel threads (and tapered threads when using a non-threaded entry) require a CMP sealing washer or integral O-ring face seal (where available) to maintain IP66, 67 and 68 (when applicable). It is the installer's responsibility to ensure the IP rating is maintained at the interface.  
 Note: When fitted to a threaded entry, all tapered threads will automatically provide an ingress protection rating of IP66.
- A CMP earth tag should be used when it is necessary to provide an earth bond connection. CMP earth tags have been independently tested to comply with Category B rating specified in IEC 62444 (there are no ratings stated in IEC 60079-0). Ratings are shown in the associated table. CMP earth tags slip over the cable gland or accessory entry thread from inside/outside the enclosure and must be secured with a locknut (if fitted internally).

CMP Earth Tag Size	Short Circuit Ratings Symmetrical Fault Current (kA) for 1 second
20	3.06
25	4.06
32	5.40
40	7.20
50	10.40
63	10.40
75	10.40

### SPECIFIC CONDITIONS OF USE

- The PX78\* unions shall only be fitted to enclosures where the temperature, at the point of mounting, does not exceed -60°C to +85°C.
- The interfaces between the male thread of the Union adaptor/reducer and an associated enclosure and between the female thread of the union adaptor/reducer and the cable entry device cannot be defined. Therefore, it is the installer's responsibility to ensure that the appropriate ingress protection level is maintained at these interfaces.

### ACCESSORIES

The following accessories are available from CMP Products, as optional extras, to assist with fixing, sealing and earthing:  
 Locknut | Earth Tag | Serrated Washer | Entry Thread (I.P.) Sealing Washer

CMP Products Limited on its sole responsibility declares that the equipment referred to herein conforms to the requirements of the ATEX Directive 2014/34/EU and UK statutory requirements SI 2016 No. 1107 (as amended). This is shown in the following harmonised/designated standards;  
 EN IEC 60079-0:2018, EN 60079-1:2014, EN IEC 60079-7:2015 + A1:2018, EN 60079-31:2014

Malcolm Webber - Product Engineering Manager - (Authorised Person)  
 CMP Products Limited, Cramlington, NE23 1WH, UK

EU Economic Operator: CMP Products Germany GmbH. Address: Lukasstraße 25a, 52070 Aachen  
 17th March 2020



Notified Body: CML B.V., Koopvaardijweg 32, 4906CV Oosterhout, The Netherlands

Approved Body: Eurofins E&E CML Limited, Newport Business Park, New Port Road, Ellesmere Port, CH65 4LZ

METRIC													NPT													Installation Torque (Nm)
Ordering Reference (Brass, Metric)	Male Forward Thread Size	Minimum Thread Length	Female Rear Thread Size	Max. Protrusion Length	Across Flats Hex	Across Corners Ø	Diameter over Cores	Max. number of Cores	Ordering Reference (Brass, NPT)	Male Forward NPT Thread Size	Minimum NPT Thread Length (in)	Female Rear Thread Size	Max. Protrusion Length	Across Flats Hex	Across Corners Ø	Diameter over Cores	Max. number of Cores									
PX789REXDM2M2	M20 x 1.5	15.0	M20 x 1.5	64.0	46.0	50.3	12.6	21	PX789REXDT111	1/2"	0.79	1/2"	64.0	46.0	50.3	12.6	21	7								
PX789REXDM3M3	M25 x 1.5	15.0	M25 x 1.5	71.0	50.0	54.7	17.5	30	PX789REXDT212	3/4"	0.80	3/4"	71.0	50.0	54.7	17.5	30	10								
PX789REXDM4M4	M32 x 1.5	15.0	M32 x 1.5	76.0	60.0	65.7	23.6	38	PX789REXDT313	1"	0.98	1"	76.0	60.0	65.7	23.6	50	15								
PX789REXDM5M5	M40 x 1.5	15.0	M40 x 1.5	84.0	65.0	71.2	30.0	59	PX789REXDT414	1-1/4"	1.01	1-1/4"	84.0	65.0	71.2	30.0	59	25								
PX789REXDM6M6	M50 x 1.5	15.0	M50 x 1.5	97.0	75.0	82.2	41.0	115	PX789REXDT515	1-1/2"	1.03	1-1/2"	97.0	75.0	82.2	36.6	115	30								
PX789REXDM7M7	M63 x 1.5	15.0	M63 x 1.5	110.0	90.0	98.7	53.7	140	PX789REXDT616	2"	1.06	2"	110.0	90.0	98.7	47.9	115	45								
PXREX789DM8M8	M75 x 1.5	15.0	M75 x 1.5	125.0	100.0	109.7	64.2	140	PXREX789DT717	2 1/2"	1.57	2 1/2"	128.0	100.0	109.7	59.9	140	45								
PXREX789DM9M9	M90 x 2.0	20.0	M90 x 2.0	148.0	120.0	131.7	75.3	140	PXREX789DT818	3"	1.63	3"	148.0	120.0	131.7	75.3	140	45								

*All dimensions shown are in millimetres unless otherwise stated.  
 For material options please add the following suffix to the Ordering Reference; Brass (no suffix required), Nickel Plated Brass "5", 316 Grade Stainless Steel "4", Copper Free Aluminium "1"*

METRIC													NPT													Installation Torque (Nm)
Ordering Reference (Brass, Metric)	Male Forward Thread Size	Minimum Thread Length	Female Rear Thread Size	Max. Protrusion Length	Across Flats Hex	Across Corners Ø	Diameter over Cores	Max. number of Cores	Ordering Reference (Brass, NPT)	Male Forward NPT Thread Size	Minimum NPT Thread Length (in)	Female Rear Thread Size	Max. Protrusion Length	Across Flats Hex	Across Corners Ø	Diameter over Cores	Max. number of Cores									
PX784REXDM2M2	M20 x 1.5	15.0	M20 x 1.5	62.0	46.0	50.3	12.6	21	PX784REXDT111	1/2"	0.79	1/2"	62.0	46.0	50.3	12.6	21	7								
PX784REXDM3M3	M25 x 1.5	15.0	M25 x 1.5	66.0	50.0	54.7	17.5	30	PX784REXDT212	3/4"	0.80	3/4"	66.0	50.0	54.7	17.5	30	10								
PX784REXDM4M4	M32 x 1.5	15.0	M32 x 1.5	70.0	60.0	65.7	23.6	38	PX784REXDT313	1"	0.98	1"	70.0	60.0	65.7	23.6	50	15								
PX784REXDM5M5	M40 x 1.5	15.0	M40 x 1.5	75.0	65.0	71.2	30.0	59	PX784REXDT414	1-1/4"	1.01	1-1/4"	75.0	65.0	71.2	30.0	59	25								
PX784REXDM6M6	M50 x 1.5	15.0	M50 x 1.5	95.0	75.0	82.2	41.0	115	PX784REXDT515	1-1/2"	1.03	1-1/2"	95.0	75.0	82.2	36.6	115	30								
PX784REXDM7M7	M63 x 1.5	15.0	M63 x 1.5	104.0	90.0	98.7	53.7	140	PX784REXDT616	2"	1.06	2"	104.0	90.0	98.7	47.9	115	45								
PXREX784DM8M8	M75 x 1.5	15.0	M75 x 1.5	118.0	100.0	109.7	64.2	140	PXREX784DT717	2 1/2"	1.57	2 1/2"	126.0	100.0	109.7	59.9	140	45								
PXREX784DM9M9	M90 x 2.0	20.0	M90 x 2.0	141.0	120.0	131.7	75.3	140	PXREX784DT818	3"	1.63	3"	146.0	120.0	131.7	75.3	140	45								

*All dimensions shown are in millimetres unless otherwise stated.  
 For material options please add the following suffix to the Ordering Reference; Brass (no suffix required), Nickel Plated Brass "5", 316 Grade Stainless Steel "4", Copper Free Aluminium "1"*



Glasshouse Street • St. Peters • Newcastle upon Tyne • NE6 1BS  
 Tel: +44 191 265 7411 • Fax: +44 1670 715 464  
 E-Mail: customerservices@cmp-products.co.uk • Web: www.cmp-products.com

F1482		
	REVISION	DATE
UKEX	0	04/21
IFS	10	03/24
ATEX / IECEX	4	04/19
cCSAus	3	-

# INSTALLATION FOR CMP UNION TYPES PX789REX & PX784REX

- 1. Entry Item
- 2. Serrated Flamepath
- 3. Nut
- 4. 90° (or 45°) Conduit Connector
- 5. Washer
- 6. Resin Dam
- 7. Compound Tube
- 8. Thread Shield

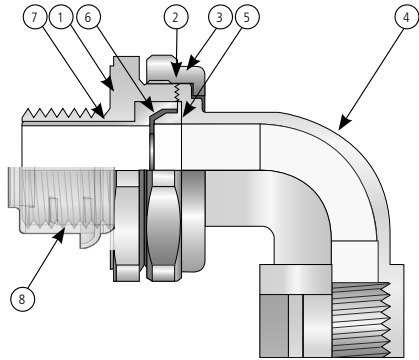

## PLEASE READ ALL INSTRUCTIONS CAREFULLY BEFORE BEGINNING THE INSTALLATION

1. Prepare the cable by removing the outer sheath from the cores so that they are exposed within the Compound Tube when finally assembled.



2. Remove any bedding or fillers from around the cable cores. If the cable cores have screens, these should be unwound and then twisted together to form a single core. This single core and/or any drain wires present should be sleeved with some heat shrink tubing.

Electrical tape **MUST** be wrapped around the tips of the cable cores. This is to ensure the cable cores are together and also to cover any sharp edges that could potentially tear the Resin Dam during installation.



3. Unscrew the Nut (3) and the Conduit connector (4) and pass down the cable/cores

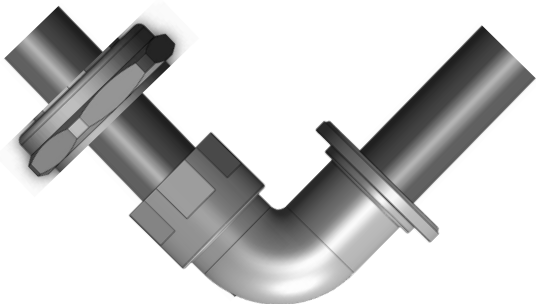

4. Feed the cables/cores through the Entry Item / Resin Dam / Washer

If the installation uses only cores (i.e. no cable sheath) then electrical tape must be wrapped around the cores at the position at which it will engage the resin dam.

Use this guide to position the tape as shown (guide length "L")

Reassemble the Union

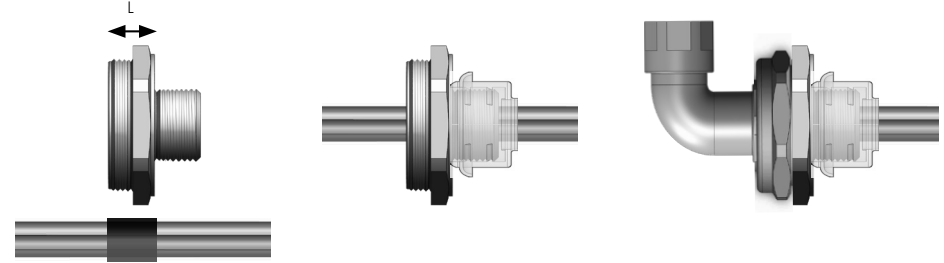

5. Mix the Resin and apply as per RapidEx instructions.

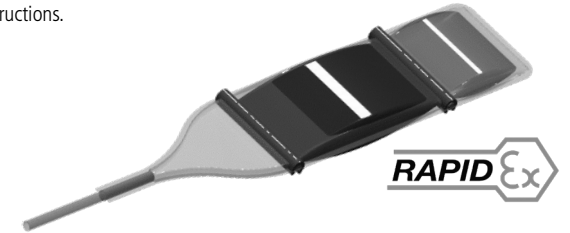

6. When the Resin has cured, the Entry Item (1) should be removed from the assembly and fully tightened into the apparatus.

Tighten the Conduit Connector (4) onto the conduit and then tighten to the Entry Item (1) using the Nut (3) to complete the installation.

