



TECHNICAL DATA

ADAPTOR TYPE : 783, 793
 INGRESS PROTECTION : IP66, IP67 & IP68 (when fitted with CMP sealing accessories)
 SERVICE TEMPERATURE : -60 to +200°C
 PROCESS CONTROL SYSTEM : ISO 9001
 : ISO/IEC 80079-34:2011

EXPLOSIVE ATMOSPHERES CLASSIFICATION

ATEX CERTIFICATION No : CML 18ATEX1306U
 ATEX CERTIFICATION CODE : Ⓜ II 2G Ex db IIC Gb, Ex eb IIC Gb, II 1D Ex ta IIIC Da Ⓜ I M2 Ex db I Mb, Ex eb I Mb
 UKEX CERTIFICATION No : CML 21UKEX1216U
 UKEX CERTIFICATION CODE : Ⓜ II 2G Ex db IIC Gb, Ex eb IIC Gb, II 1D Ex ta IIIC Da Ⓜ I M2 Ex db I Mb, Ex eb I Mb
 IECEx CERTIFICATION No : IECEx CML 18.0171U
 IECEx CERTIFICATION CODE : Ex db I Mb, Ex eb I Mb, Ex db IIC Gb, Ex eb IIC Gb, Ex ta IIIC Da

IMPORTANT NOTES FOR INSTALLERS

1. Read all instructions before beginning installation. Installation shall only be performed by competent, suitably trained personnel (in accordance with EN/IEC 60079-14) using the correct tools; spanners should be used for tightening.
2. Inspection and maintenance shall only be performed by competent, suitably trained personnel (in accordance with EN/IEC 60079-14 (Initial Inspection) and EN/IEC 60079-17).
3. The interface between a cable entry device and its associated enclosure / cable entry will require additional sealing to achieve ingress protection (IP) ratings higher than IP54. The minimum protection level is IP54 for explosive gas atmospheres and IP6X for explosive dust atmospheres. Parallel threads (or tapered threads when using a non-threaded entry) require a CMP sealing washer or integral O-ring face seal (where available) to maintain IP66, 67 and 68 (when applicable).
 Note: When fitted to a threaded entry, all tapered threads will automatically provide an ingress protection rating of IP66.
4. Adaptors are manufactured from Brass, Nickel Plated Brass, Stainless Steel or Mild Steel. The end user shall consider the performance of these materials with regard to attack by aggressive substances that may be present in the hazardous area. Consideration should be given to potential degradation due to galvanic corrosion at the interface of dissimilar metallic materials. It is the end user's responsibility to ensure the equipment materials are suitable for their final installation location. If in doubt consult CMP Products Limited.
5. Ex db marked Adaptors can only be supplied with metric or NPT entry threads.
6. Equipment is not intended to be repaired. If damaged, equipment must be replaced.
7. A CMP earth tag should be used when it is necessary to provide an earth bond connection. CMP earth tags have been independently tested to comply with Category B rating specified in IEC 62444 (there are no ratings stated in IEC 60079-0). Ratings are shown in the associated table. CMP earth tags slip over the cable gland or accessory entry thread from inside the enclosure and must be secured with a locknut.

SCHEDULE OF LIMITATIONS

None

ORDERING

e.g. 783 - D - M - 2 - M - M - 2 - F - M - 2 - F - 5
 = Dual Certified Ex d & Ex e - M20 (M) x M20 (F) x M20 (F) - Nickel Plated Brass

* Any combination of Male (M) / Female (F) threads is available e.g. (M) X (M) X (M), (F) X (F) X (F), (M) X (F) X (M)

ACCESSORIES

The following accessories are available from CMP Products, as optional extras, to assist with fixing, sealing and earthing:
 Locknut | Earth Tag | Serrated Washer | Entry Thread (I.P.) Sealing Washer

CMP Earth Tag Size	Short Circuit Ratings Symmetrical Fault Current (kA) for 1 second
20	3.06
25	4.06
32	5.40

CMP Products Limited on its sole responsibility declares that the equipment referred to herein conforms to the requirements of the ATEX Directive 2014/34/EU and UK statutory requirements SI 2016 No. 1107 (as amended). This is shown in the following harmonised/designated standards;

-EN IEC 60079-0:2018, EN 60079-1:2014, EN IEC 60079-7:2015 +A1: 2018, EN 60079-31:2014

Malcolm Webber - Product Engineering Manager (Authorised Person)
 CMP Products Limited, Cramlington, NE23 1WH

EU Economic Operator: CMP Products Germany GmbH. Address: Lukasstraße 25a, 52070 Aachen
 17th March 2020

CE 2776 Notified Body: CML B.V., Koopvaardijweg 32, 4906CV Oosterhout, The Netherlands

UK CA 2503 Approved Body: Eurofins E&E CML Limited, Newport Business Park, New Port Road, Ellesmere Port, CH65 4LZ



ASSEMBLY FITTING INSTRUCTIONS FOR INTALLATION OF CMP Y AND T ADAPATOR TYPE 783(Y), 793(T)

INCORPORATING EU DECLARATION OF CONFORMITY TO DIRECTIVE 2014/34/EU AND UK STATUTORY REQUIREMENTS SI 2016 No. 1107 (AS AMENDED)

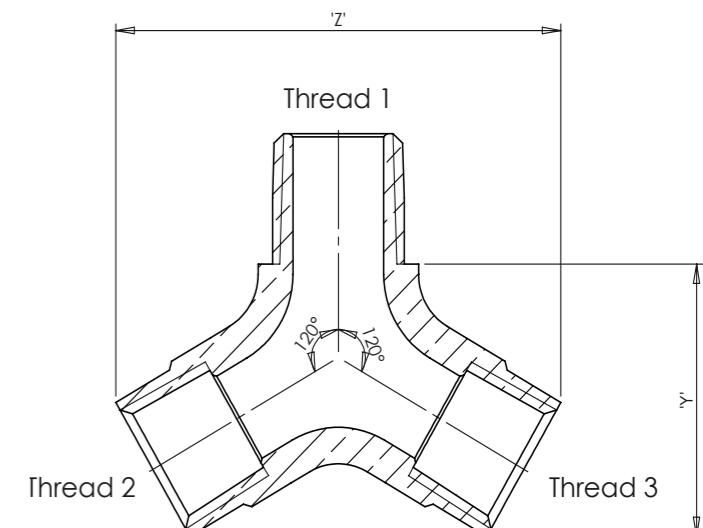

Product Selection Table									
Product	Ordering Reference	Bore Diameter	Thread 1* (Entry Thread)	Thread 2*	Thread 3*	Thread Length	Protrusion Length 'Y'	Protrusion Length 'Z'	Width
793	793DM2MM2FM2F	14.7	M20	M20	M20	15.0	36.5	66.0	25 - 27
793	793DT1MT1FT1F	14.7	1/2" NPT	1/2" NPT	1/2" NPT	19.9	33.0	66.0	25 - 27
793	793DM3MM3FM3F	18.9	M25	M25	M25	15.0	45.0	70.5	30 - 32
793	793DT2MT2FT2F	18.9	3/4" NPT	3/4" NPT	3/4" NPT	20.2	40.0	70.5	30 - 32
793	793DM4MM4FM4F	25.9	M32	M32	M32	15.0	56.5	83.5	37 - 39
793	793DT3MT3FT3F	25.9	1" NPT	1" NPT	1" NPT	25.0	46.5	83.5	37 - 39
783	783DM2MM2FM2F	14.7	M20	M20	M20	15.0	48.0	73.0	25 - 27
783	783DT1MT1FT1F	14.7	1/2" NPT	1/2" NPT	1/2" NPT	19.9	48.0	73.0	25 - 27
783	783DM3MM3FM3F	18.9	M25	M25	M25	15.0	48.0	76.9	30 - 32
783	783DT2MT2FT2F	18.9	3/4" NPT	3/4" NPT	3/4" NPT	20.2	48.0	76.9	30 - 32
783	783DM4MM4FM4F	25.9	M32	M32	M32	15.0	56.5	92.5	37 - 39
783	783DT3MT3FT3F	25.9	1" NPT	1" NPT	1" NPT	25.0	56.5	92.5	37 - 39

All dimensions shown are in millimetres unless otherwise stated

783 - Y ADAPTOR (Pictured)
 793 - T ADAPTOR

FIS16		
Certification	Revision	Date
UKEX	0	04/21
IFS	8	04/24
ATEX / IECEx	6	03/21



Glasshouse Street • St. Peters • Newcastle upon Tyne • NE6 1BS
 Tel: +44 191 265 7411 • Fax: +44 1670 715 646
 E-Mail: customerservices@cmp-products.com • Web: www.cmp-products.com

INSTALLATION INSTRUCTIONS FOR CMP ACCESSORY 783(Y), 793(T)

Fitting instructions relevant for both Y and T adaptors

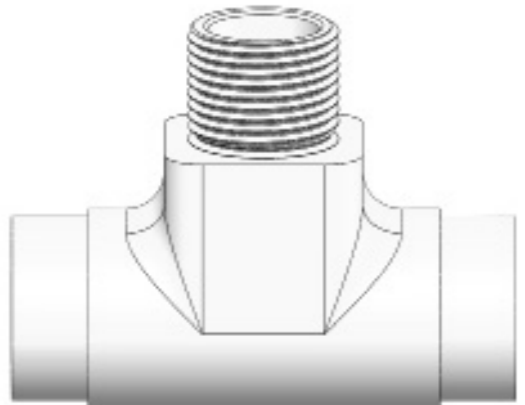

793 - T ADAPTOR

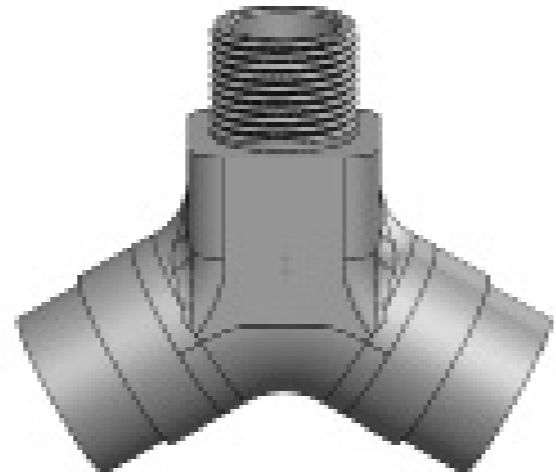

783 - Y ADAPTOR (Pictured)

- 1. Add entry thread seal if required
Tighten into enclosure / equipment by hand initially

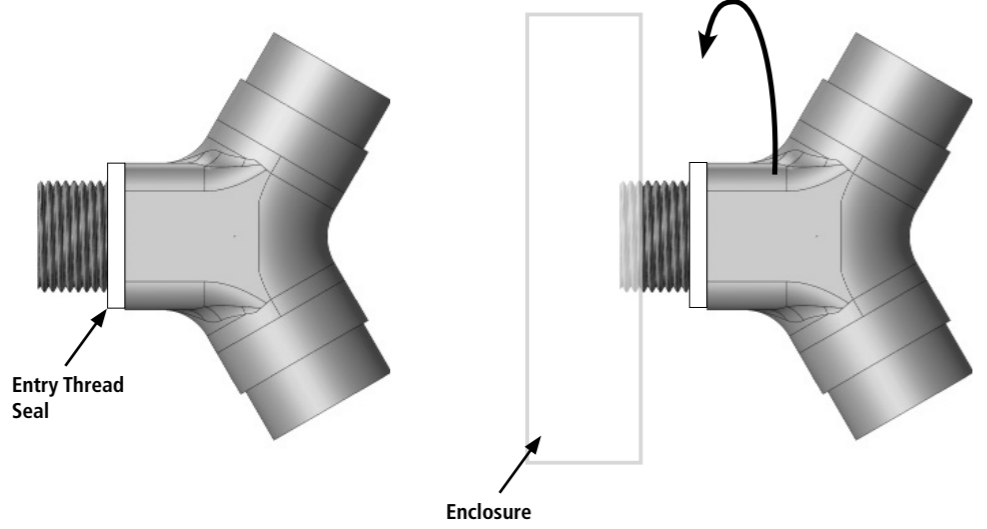

- 2. Complete tightening with spanner if necessary

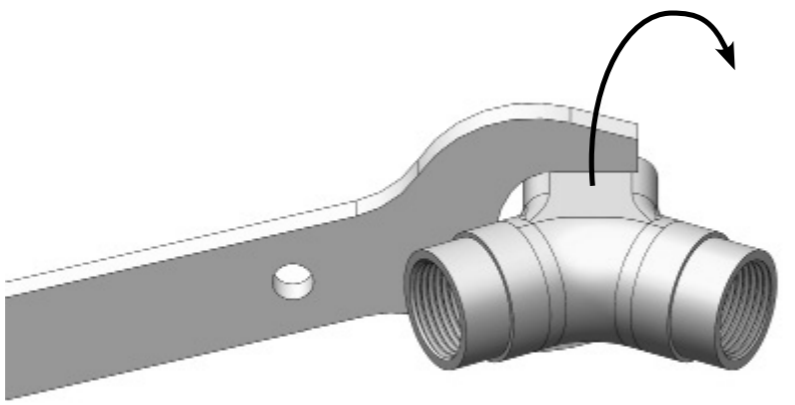

NPT threads will lock before all threads are used

- 3. Attach further equipment / cable glands to remaining entries

